



ChipMax 484V

Features

- Compact, durable and powerful
- High production (100+ tons per hour)
- Choice of 2-Knife or 4-Knife Chipping Rotor for fuel chips (19-30 mm) or micro chips (3-12 mm)
- Chipper housing offers easy access to rotor and anvil
- Rotating discharge chute for top loading of trailers and 290° of rotation for broadcast spreading of chips.
- Hydrostatic driven blower for stronger chip discharge
- CAT C-18, 765 hp engine (EPA Flex for USA)
- Parker IQAN™ control system with Radio Remote Control
- Track mounted, or trailer, truck mounted with hydraulically operated 360° swing bearing.
- Road legal width and weight (for frequent moves between jobs)

Description

Compact yet enormously productive, the ChipMax 484 is an extreme-duty biomass production workhorse. Its main components such as the rotor, chipper box and feed system are significantly stronger than any other chipper in its class, providing owners with years of trouble free service. Featuring two rotor options, the ChipMax can make high-quality fuel chips custom sized from 19–30 mm or “micro-chips” from 3–12 mm. These “micro-chips” produce a consistent fiber length that dramatically reduces the overall cost of producing pellets as well as improves the function of small boilers.

Feed Conveyor and Rotor

The 12' x 48" feed conveyor is designed with troughed sides, impact plate in the bottom, heavy duty head and tail pulley and is driven by an extreme high-torque Poclain hydraulic motor (an optional 8' conveyor is available.) Owners have a choice between an apron-style conveyor (prevents material spillage) or four-strand heavy-duty chain (allows rocks and dirt to be



screened prior to chipping.) The 30" upper feed roller with a built-in high-torque Poclain hydraulic motor lifts for full and easy access to the heavy-duty rotor and anvil. The 48" wide x 40" diameter 2-knife or 4-knife drum rotor is engineered with a 6" flame cut pocket design, making it significantly stronger and more durable than anything in the industry.

Discharge Chute

The collapsible hydraulic operated chip discharge chute facilitates top loading of chip trailers. It also features a hydrostatic driven blower for stronger chip discharge that automatically increases power when needed (without any wear or excess power consumption) and a chip deflector that is hydraulically actuated into position when top loading. The discharge chute hydraulically rotates 290 degrees to distribute chips in multiple areas, which minimizes truck relocation during loading.

Power Unit

The ChipMax is powered by a Cat C-18, 765 hp diesel engine (EPA Flex for USA). To further its unique design, it is equipped with an extra-large AKG radiator, Flexaire auto-reversing fan, PT Tech PTO, IntelliGrind control system by Parker IQAN™ for increased monitoring and protection, and radio remote control with full mechanical backup to run all vital functions of the machine.

General

Adding to its versatility, the ChipMax V is available as a portable [pintle hook or 5th wheel mounting hitch], track, or truck-mounted unit and is road legal in both width and weight (for frequent moves between jobs.)

Specifications

Feed Conveyor	Apron or Chain
Length	12' (or optional 8')
Width	48"
Motor	High-torque Poclairn
Top Feed Roll	
Dimension	48" wide x 30" diameter
Motor	High-torque Poclairn
Rotor	2-knife or 4-knife drum
Dimension	48" wide x 40" diameter
Discharge Chute	Vertical w/ Directional Chute
	290° Rotation
Throughput	Up to 100+ tons/hr.
Swing Gear*	360° Rotation
	*Optional Feature

Hydraulics

Type Hydrostatic / Rexroth, Sauer, Poclairn
PT Tech Gearbox

Power

Engine CAT C18; 765 hp (EPA Flex for USA)
Drive V belt with guarding
Flexaire® Fan Reversing pitch radiator fan that reverses airflow every 5-15 minutes automatically (adjustable)

Fuel Tank

Capacity 250 gallons (946 liters)

Electrical

IQAN™ PLC and radio remote control for all functions

Tracks

Berco #4 or #5

At CBI, we build machines based on **total ownership** rather than compromising quality, and this allows us to **custom-tailor** our machines to fit your individual business needs. To discuss other specially engineered configurations, please call (603) 382-0556 today!

ChipMax 484VT

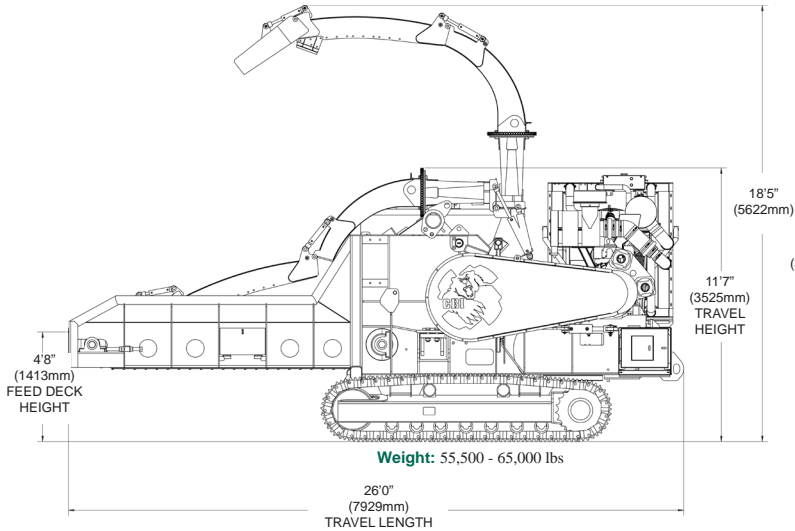

Truck-Mounted

ChipMax 484VR

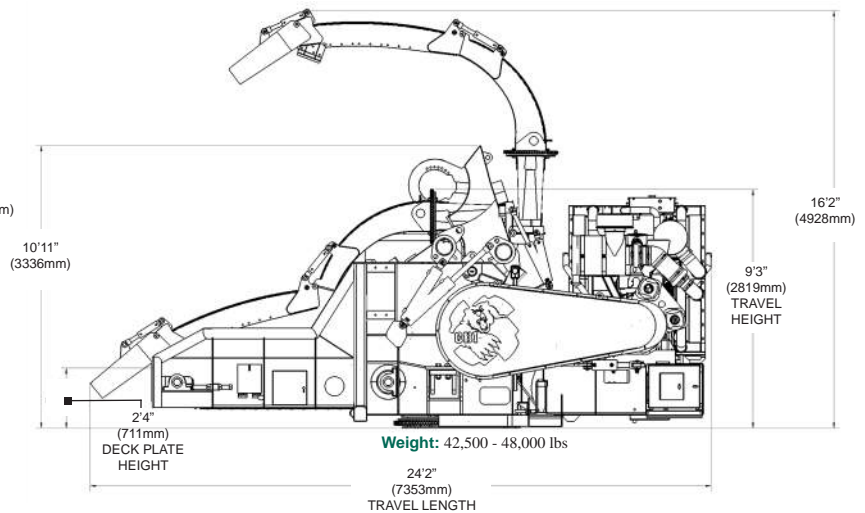

Euro 3-Axle Trailer - 24.9 Metric Tons

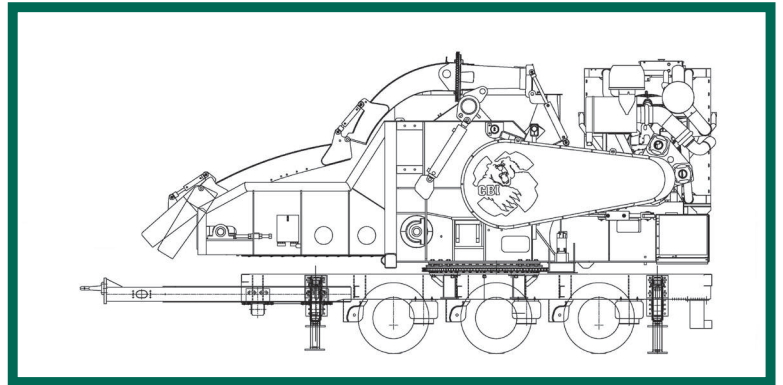

The CBI difference: Fuel the Future.™

Continental Biomass Industries, Inc.

World's Best Stationary and Portable Material Recovery Systems

22 Whittier Street, Newton, NH 03858

Phone: 603-382-0556 Fax: 603-382-0557

Web: cbi-inc.com Email: info@cbi-inc.com

Distributed by: